

---

# AEC TUNNEL LIGHTING

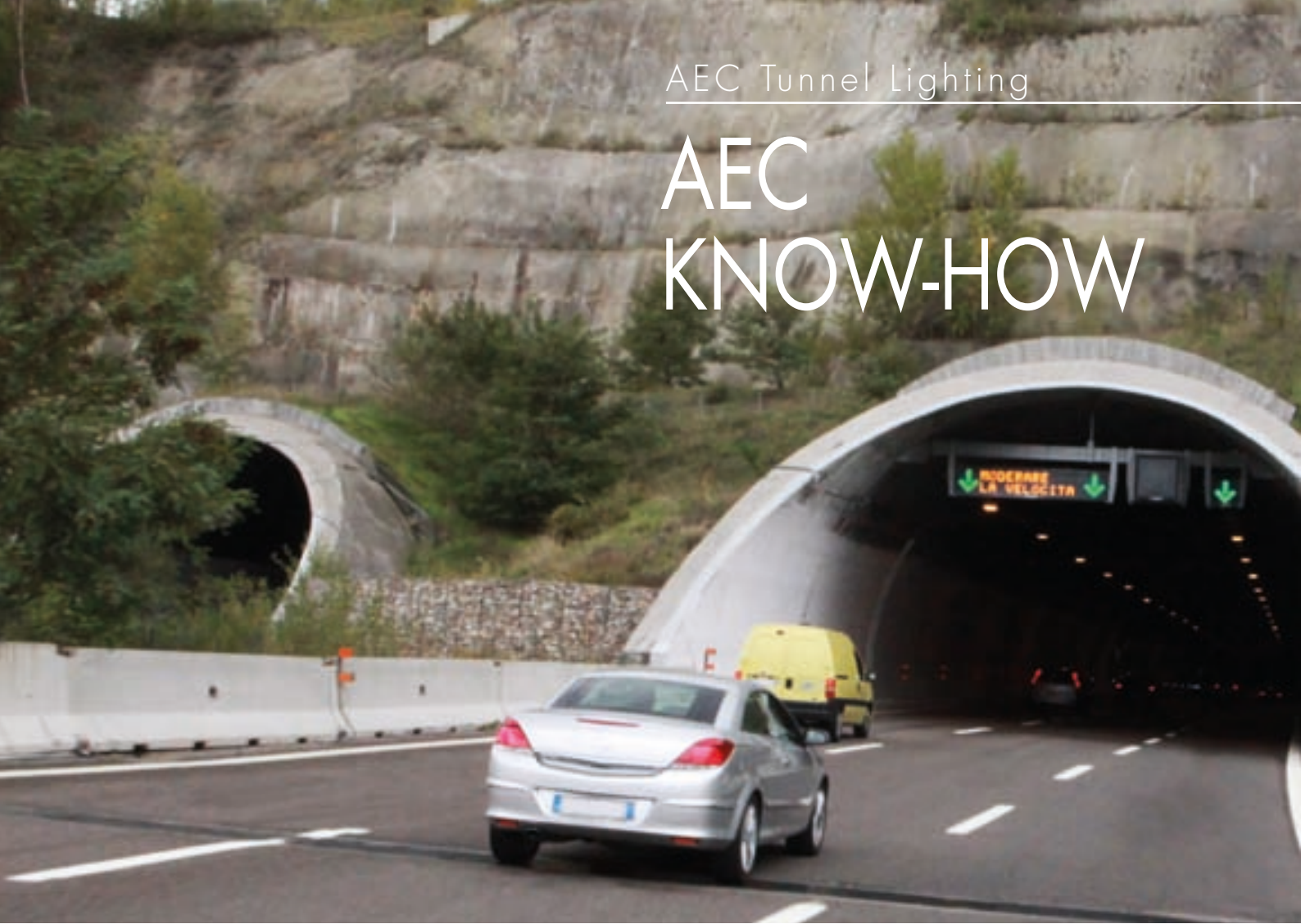

# AEC KNOW-HOW



AEC tunnel range of products come from the combination of years of experience in tunnel lighting and the application of the latest technologies developed by AEC R&D.

The series is the result of a multi-disciplinary design study, accomplished within the modern production units and sophisticated test labs, where safety and performances are tested by qualified and constantly updated personnel.

AEC follows the product development in every phase: from optical to mechanical and electronic design. The Company monitors the development of LED technology constantly investing in it.

AEC tunnel range of products are equipped with "Comfort Light Optic": the high performing optical system developed by AEC for its LED technology devices.

Comfort Light Optic is an optical system able to guarantee a reduced glaring effect, while maintaining the same performances.



## THE USE OF “COMFORT LIGHT OPTIC” ALLOWS:

### To maximise luminous efficiency

AEC “Comfort Light Optic” gives great advantages in terms of luminous efficiency, minimising losses for refraction and reflection inside the optical system. “Comfort Light Optic” guarantees a lower density of dirt, maintaining product performance unaltered even within “aggressive” scenarios like tunnels where optical performances and luminous efficiency tend to decrease due to the polluting effect.

### To obtain the best lighting performances

AEC “Comfort Light Optic” achieves maximum spacing between poles and optimum uniformity. It also contributes to maximising luminance and lighting levels thanks to a high efficiency rate. The high quality materials chosen for the optic design also influence its performances.

The optical system is composed of a reflector allowing to adapt the photometry according to the type of application chosen.

### To protect the LED source

AEC uses a highly transparent and mechanically resistant glass to guarantee the total IP degree and protect the LED source against impacts or external agents.

### To guarantee photobiological safety

“Comfort Light Optic” eliminates the risk of damage to the retina in compliance with the safety requirements imposed by the standard relating to laser sources (EN 62471).

The reference standard prescribes a specific classification in order to preserve the observer from potential photochemical and photobiological damages.

According to this classification, AEC luminaires fall within the EXEMPT GROUP category (no photobiological risk).



# AEC TUNNEL SYSTEM

Thanks to the continuous development featuring the "Tunnel Lighting" division, AEC offers its users integrated lighting systems able to meet the high quality standards required by this type of application.

Safety, efficiency and costs reduction are at the base of the "AEC tunnel system" and assure the company the acquisition of prestigious projects all over the world.

---

# TUNNEL LONGITUDINAL PARTITION ACCORDING TO LEVELS OF DANGER

50 m before entrance zone	50m after entrance zone <b>black-hole effect</b>	100m after zone 2	Central part Damages to vehicules Driver carelessness	100m before exit zone	50m before exit zone <b>glaring effect</b>	50m after exit zone
ZONE 1	ZONE 2	ZONE 3	ZONE 4	ZONA 3	ZONE 2	ZONE 1

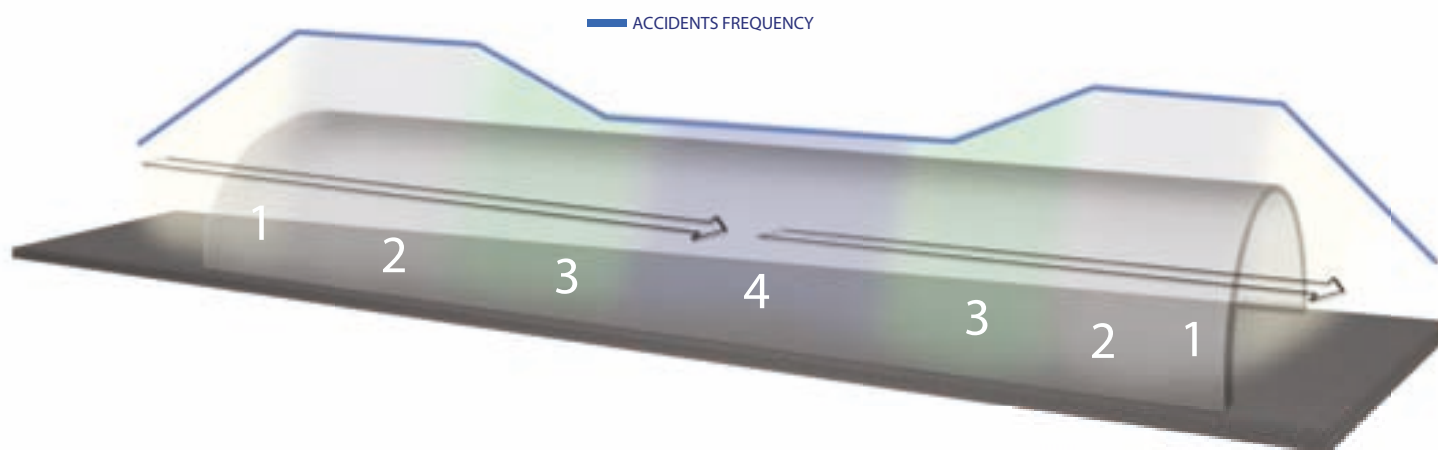

## SAFETY

A well deigned tunnel lighting system must guarantee adequate safety conditions both at night and during daytime, with the aim of providing the driver with the best visual comfort. The visual conditions have to be at least equal to those of the previous or subsequent open roads. The photometric features meeting the safety requirements set by the international standards are:

- Adequate luminance, uniformity and distribution levels on the road surface and tunnel walls.
- Reduction of glaring effects.
- Reduction of flicker effect.

AEC LED technology finds one of the most efficient applications in tunnel lighting. Quality white light, luminous flux directionality and great uniformity contribute to a significant increase of the safety conditions within the covered section.

It is known that the higher percentage of accidents mainly occur in the transition areas where efficient lighting should avoid the "black hole effect" at the entrance and the "glaring effect" at the exit, allowing the driver to safely approach the tunnel.

The compliance with the safety requirements referring

to artificial lighting must take into account both the progressive adaptation of the eye and the different levels of luminance required along the covered section.



## EFFICIENCY

The right approach to tunnel lighting is for AEC an incumbent obligation towards its internal market. Italy is in fact the EU country with the highest number of tunnels and the costs optimisation is a crucial issue for all the operators involved.

AEC provides high-performing LED lighting systems guaranteeing:

### **Energy saving and costs reduction**

The use of LED technology

allows to reduce energy costs and management costs in terms of maintenance.

AEC team is able to provide its customers with a valuation of costs and savings, according to the installation life time.

### **Versatile solutions**

Thanks to its wide variety of optics and to the modularity of its luminaires, AEC offers its customers a complete range of products able to perfectly adapt to different applications.

### **Eco-sustainability**

AEC designs and produces lighting solutions able to limit CO<sub>2</sub> emissions. Reducing the environmental impact in lighting is one of the goals the Company imposes itself in order to win important environmental challenges.

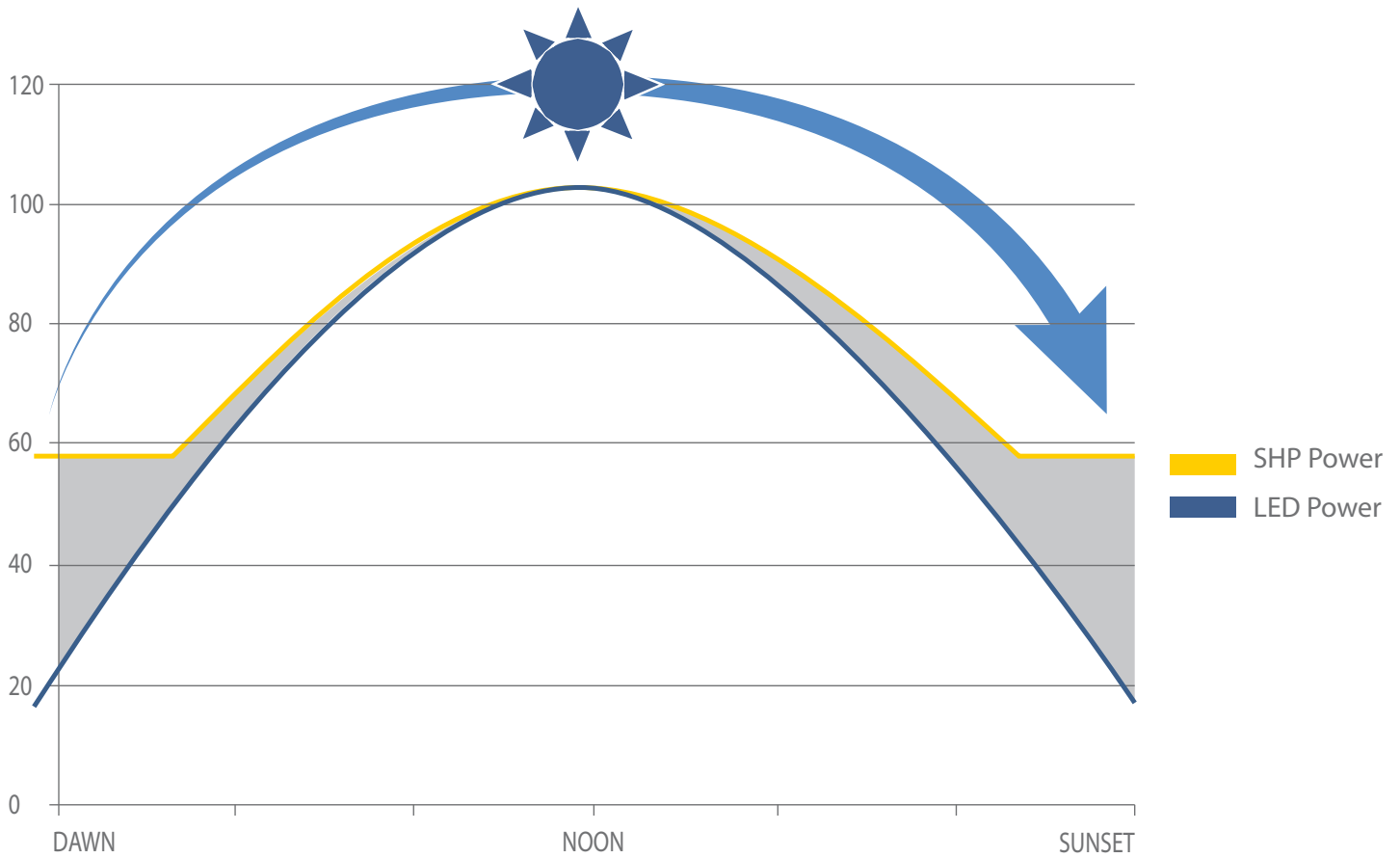

## COSTS REDUCTION

One of the advantages of LED technology, in addition to the reduction of energy consumption and maintenance costs, is the possibility of optimising the threshold lighting dimming according to the external lighting conditions. Discharge solutions suffer of some technological limits due to the impossibility of dimming the sources below 60% of their flow (with a ferromagnetic power supply unit). As a consequence, threshold

lighting works in a higher lighting regime respect to the perceptive and energetic needs.

AEC LED technology optimises the dimming levels up to 15-20% of their initial flux, maintaining the necessary perceptive conditions and guaranteeing a significant consumption reduction with an estimated 10-15% energy saving.

A discharge luminaire at a regime of 60% is featured by

a power factor of less than 0.85. AEC LED luminaires for tunnel lighting reach a power factor of more than 0.9 even with a 30-40% dimming. It follows that the use of AEC LED devices also allows to reduce the power consumption of the whole installation.

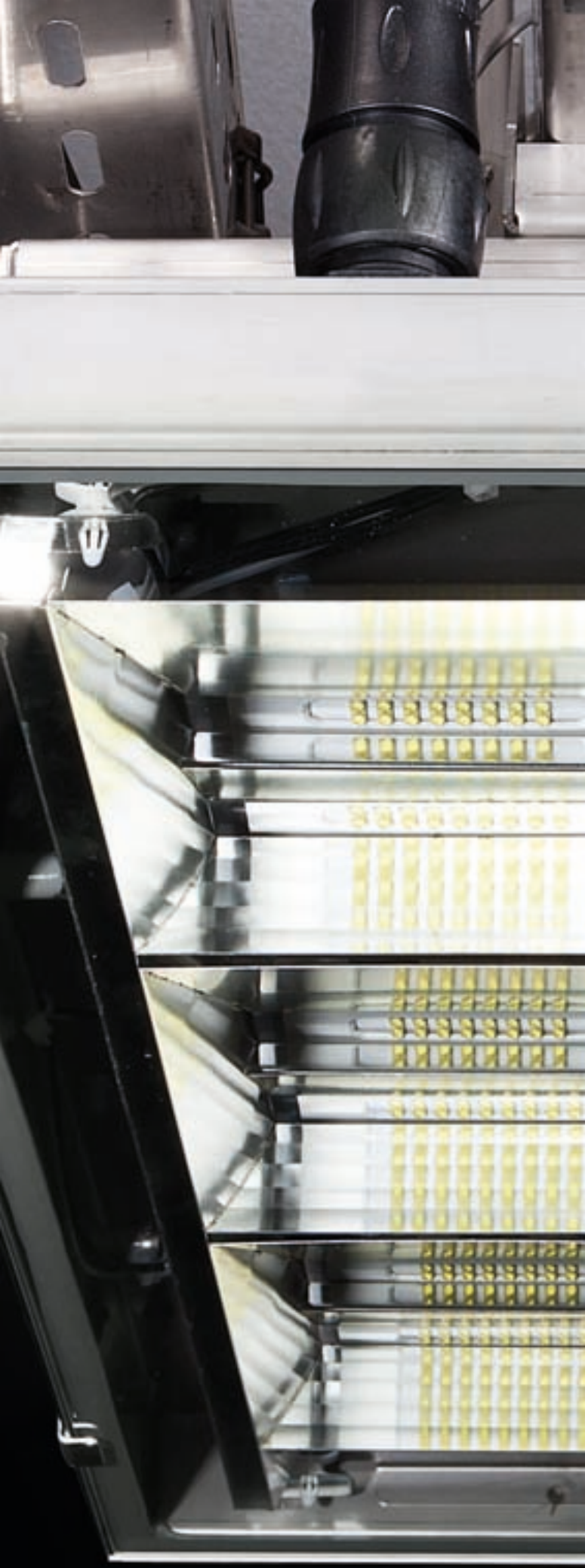

AEC Tunnel Lighting

# AEC CERTIFIED QUALITY

AEC offers its customers integrated lighting systems, synonym of RELIABILITY.

In a competitive sector such as the one of tunnels, this concept is relevant in order to guarantee the best performances of AEC tunnel lighting.

AEC is equipped with all the tools able to assure different solutions according to different installation requirements.





IP (powder) test

The Company carries out all the tests required by product standards in its UL certified laboratory: from electrical safety and electromagnetic compatibility to reliability of materials and components. A team of experts is constantly engaged in the research and development of the more efficient and advanced solutions. The ENEC and IQNet certification enhance AEC commitment and build credibility and reliability

around the entire range of products.

Within AEC photometric labs, AEC staff develops high efficient optical systems and provides customers with all the certified photometric and radiometric data according to:

- UNI EN 13032-1 2012, Measurement and presentation of photometric data of lamps and luminaire.



Pre-Burning test

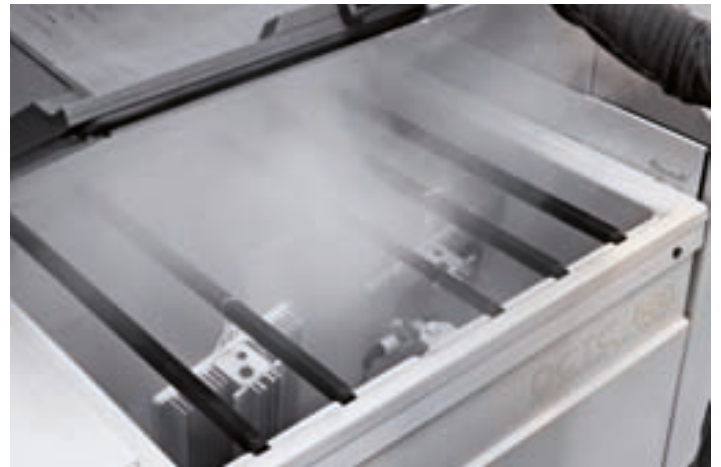

Severe environment test

- UNI 11356-2010, Protocol for the measurement of LED luminaire photometric data.
- IES LM-79-08 Electrical and Photometric Measurements of Solid-State Lighting Products, for CRI, CCT and Flux.

In accordance with the mentioned standards, AEC photometric lab is supervised by a third party: UL International Italy S.r.l.

# APPLICATION ZONES

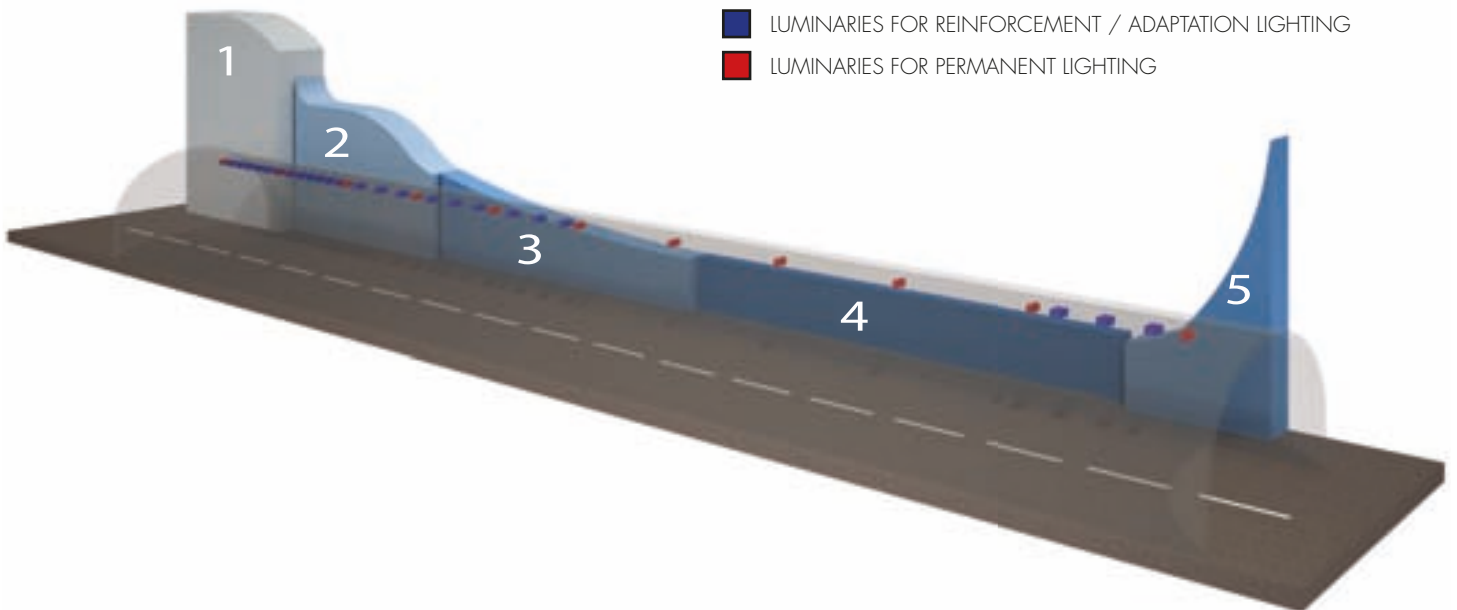



### **1 Access zone**

Part of the road immediately outside the tunnel in which an approaching driver must be able to recognize a possible obstacle; its length is equal to the stopping distance.

### **2 Threshold zone**

First part of the tunnel immediately after the portal. Its length is at least equal to the stopping distance. The difference between the luminance in the threshold zone and in the access zone should be as small as possible. The driver has to be able to recognize an obstacle from the stopping distance.

### **3 Transition zone**

Part of the tunnel following the threshold zone. Luminance levels decrease slowly in order to allow the adaptation of the driver's eyes to the lower lighting levels featuring the interior zone.

### **4 Interior zone**

Part located between the transition zone and the exit zone. Luminance levels should guarantee a safe drive.

### **5 Exit zone**

Terminal part of the tunnel where the visibility is influenced by the external brightness. In some cases an adaptive lighting can be required.

AEC Tunnel Lighting

---

# THE PRODUCT



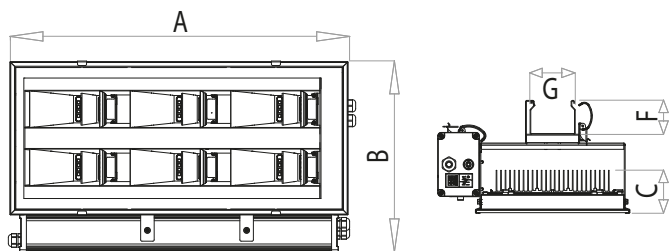

MAIN FEATURES	
<b>Applications</b>	Tunnel entry, exit lighting
<b>Optic</b>	AS: Asymmetrical optic for entrance lighting of tunnel Color temperature: 5700K (4000K upon request) CRI typical: 70 (5700K) Photobiological safety class EXEMPT GROUP LED source efficiency: 110lm/W @ 700mA, Tj=85°C
<b>Tilt angle</b>	According to lighting calculation
<b>Insulation class</b>	II
<b>Impact protection</b>	IK08
<b>Protection degree</b>	IP66 total IP65 (RS-485)
<b>Fixing</b>	Mounting system for cable ladder with manual double closing-hook and safety lock GxF: Upon request (standard 100x75mm)
<b>Gear tray</b>	Separated from the optical group, not removable
<b>Dimensions</b>	See table n.1
<b>Main reference standards</b>	EN 60598-1, EN 60598-2-3, EN 62471, EN 55015, EN 61547, EN 61000-3-2, EN 61000-3-3

DIMENSIONS - Table n.1					External P. Supply
	54	36	18	9	
F	750x425x95 (AxBxC)	580x425x95 (AxBxC)	390x425x95 (AxBxC)	390x301x95 (AxBxC)	
PLM DIM-BIP RS-485	18Kg	13Kg	9Kg	5Kg	



ELECTRIC FEATURES	
<b>Rated voltage</b>	220÷240V 50/60Hz (others upon request)
<b>LED Current</b>	700mA
<b>Power factor</b>	>0,9 (full load)
<b>Control system</b>	F: Fixed, not dimmable PLM: Single point communication module RS-485: Single point serial communication module
<b>Wiring system</b>	Branch wiring Cable FG7OM1 0.6/1kV 3x1.5mmq L.1.5mt Plug IEC309 2P+T 16A IP67 Other types of plugs and cables are available upon request
<b>Communication connector (only RS-485)</b>	Double panel connector IP65 (communication cable excluded)
<b>Communication cable RS-485</b>	3xAWG24 twisted with shield, RS-485 (120Ohm), LSZH, 0,6/1kV, length upon request
<b>Optical unit life (Ta=25°C)</b>	≥50.000hr B20L80 (including critical failures) ≥70.000hr L80, TM-21

MATERIALS	
<b>Fixing</b>	Stainless steel AISI 304 (AISI 316L upon request)
<b>Heatsink</b>	Extruded, anodized aluminium
<b>Body</b>	Stainless steel AISI 304
<b>Optic</b>	High efficiency metalized aluminium
<b>Screen</b>	Flat tempered glass 4mm
<b>Cable clamp</b>	Plastic M20x1.5 - IP68
<b>Screen safety hooks</b>	Stainless steel AISI 304

Please note that the above-mentioned product characteristics can change and need to be confirmed at the order stage.

For any information about fluxes and wattages, please visit the tunnel section at [www.aecilluminazione.com](http://www.aecilluminazione.com)

# TLED 1F S

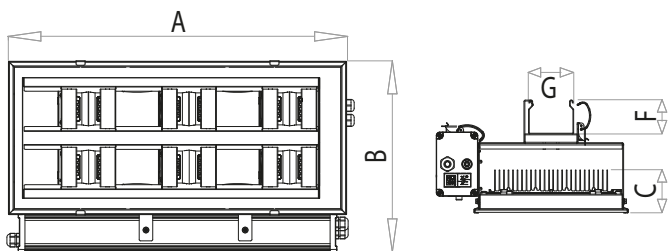

MAIN FEATURES	
<b>Applications</b>	Tunnel entry, exit lighting
<b>Optic</b>	S: Symmetrical optic for entrance lighting of tunnel Color temperature: 5700K (4000K on request) CRI typical: 70 (5700K) Photobiological safety class EXEMPT GROUP LED source efficiency: 110lm/W @ 700mA, T <sub>j</sub> =85°C
<b>Tilt angle</b>	According to lighting calculation
<b>Insulation class</b>	II
<b>Impact protection</b>	IK08
<b>Protection degree</b>	IP66 total IP65 (RS-485)
<b>Fixing</b>	Mounting system for cable ladder with manual double closing-hook and safety lock GxF: Upon request (standard 100x75mm)
<b>Gear tray</b>	Separated from the optical group, not removable
<b>Dimensions</b>	See table n.1
<b>Main reference standards</b>	EN 60598-1, EN 60598-2-3, EN 62471, EN 55015, EN 61547, EN 61000-3-2, EN 61000-3-3



ELECTRIC FEATURES	
<b>Rated voltage</b>	220÷240V 50/60Hz (others upon request)
<b>LED Current</b>	700mA
<b>Power factor</b>	>0,9 (full load)
<b>Control system</b>	F: Fixed, not dimmable PLM: Single point communication module RS-485: Single point serial communication module
<b>Wiring system</b>	Branch wiring Cable FG70M1 0.6/1kV 3x1.5mmq L.1.5mt Plug IEC309 2P+T 16A IP67 Other types of plugs and cables are available upon request
<b>Communication connector (only RS-485)</b>	Double panel connector IP65 (communication cable excluded)
<b>Communication cable RS-485</b>	3xAWG24 twisted with shield, RS-485 (120Ω), LSZH, 0,6/1kV, length upon request
<b>Optical unit life (T<sub>a</sub>=25°C)</b>	≥50.000hr B20L80 (including critical failures) ≥70.000hr L80, TM-21

MATERIALS	
<b>Fixing</b>	Stainless steel AISI 304 (AISI 316L upon request)
<b>Heatsink</b>	Extruded, anodized aluminium
<b>Body</b>	Stainless steel AISI 304
<b>Optic</b>	High efficiency metalized aluminium
<b>Screen</b>	Flat tempered glass 4mm
<b>Cable clamp</b>	Plastic M20x1.5 - IP68
<b>Screen safety hooks</b>	Stainless steel AISI 304

Please note that the above-mentioned product characteristics can change and need to be confirmed at the order stage.

DIMENSIONS - Table n.1					External P. Supply
	54	36	18	9	
F	750x425x95 (AxBxC)	580x425x95 (AxBxC)	390x425x95 (AxBxC)	390x301x95 (AxBxC)	External P. Supply
PLM DIM-BIP RS-485	18Kg	13Kg	9Kg	5Kg	

For any information about fluxes and wattages, please visit the tunnel section at [www.aecilluminazione.com](http://www.aecilluminazione.com)



# TLED OB

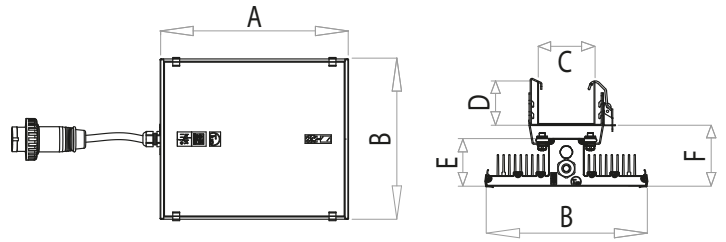

MAIN FEATURES	
<b>Applications</b>	Tunnel interior lighting
<b>Optic</b>	TA: Symmetrical optic for interior lighting of tunnels TB: Asymmetrical optic for interior lighting of tunnels TC: Asymmetrical optic for interior lighting of tunnels Color temperature: 6000K (others upon request) CRI typical: 70 (6000K) Photobiological safety class EXEMPT GROUP LED source efficiency: 120lm/W @ 525mA, Tj=25°C
<b>Tilt angle</b>	G: according to lighting calculation
<b>Insulation class</b>	II
<b>Impact protection</b>	IK08
<b>Protection degree</b>	IP66 total IP65 (RS-485)
<b>Fixing</b>	Mounting system for cable ladder with manual double closing-hook and safety lock Cx D: On request (standard 100x75mm)
<b>Dimensions</b>	See table n.1
<b>Main reference standards</b>	EN 60598-1, EN 60598-2-3, EN 62471, EN 55015, EN 61547, EN 61000-3-2, EN 61000-3-3



ELECTRIC FEATURES	
<b>Rated voltage</b>	220÷240V 50/60Hz (others upon request)
<b>LED current</b>	525mA
<b>Power factor</b>	>0,9 (full load)
<b>Control system</b>	F: Fixed, not dimmable PLM: Single point communication module RS-485: Single point serial communication module DB: Dual power with control wire
<b>Wiring system</b>	Branch wiring Cable FG7OM1 0.6/1kV 3x1.5mmq L.1.5mt Plug IEC309 2P+T 16A IP67 Other types of plugs and cables are available upon request
<b>Connector (RS-485)</b>	Panel connector IP65, integrated communication cable RS-485 type LSZH 0,6/1kV
<b>Optical unit life (Ta=25°C)</b>	≥70.000hr B20L80 (including critical failures) ≥90.000hr L80, TM-21

MATERIALS	
<b>Fixing</b>	Stainless steel AISI 304 (AISI 316L upon request)
<b>Heatsink</b>	Extruded, anodized aluminium
<b>Body</b>	Painted die-cast aluminium
<b>Optic</b>	Polycarbonate, metallic high-efficiency
<b>Screen</b>	Flat tempered glass, 4mm
<b>Cable clamp</b>	Plastic M20x1.5 - IP68
<b>Screen safety hooks</b>	Extruded, anodized aluminium

Please note that the above-mentioned product characteristics can change and need to be confirmed at the order stage.



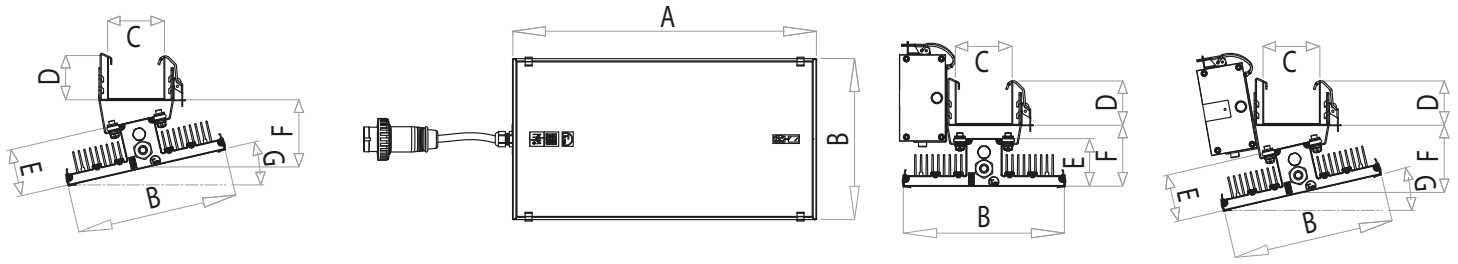

DIMENSIONS - Table n.1				
	27	36	54	
F	329x280x83mm (AxBxE) - 6Kg	329x280x83mm (AxBxE) - 6Kg	329x280x83mm (AxBxE) - 6Kg	Internal P. Supply
PLM	529x280x83mm (AxBxE) - 9,6Kg	529x280x83mm (AxBxE) - 9,6Kg	529x280x83mm (AxBxE) - 9,6Kg	
DB	529x280x83mm (AxBxE) - 9,6Kg	529x280x83mm (AxBxE) - 9,6Kg	529x280x83mm (AxBxE) - 9,6Kg	
RS-485	529x280x83mm (AxBxE) - 9,6Kg	529x280x83mm (AxBxE) - 9,6Kg	529x280x83mm (AxBxE) - 9,6Kg	
F	329x280x83mm (AxBxE) - 6Kg	329x280x83mm (AxBxE) - 6Kg	329x280x83mm (AxBxE) - 6Kg	External P. Supply
PLM	329x280x83mm (AxBxE) - 6Kg	329x280x83mm (AxBxE) - 6Kg	329x280x83mm (AxBxE) - 6Kg	
DB	329x280x83mm (AxBxE) - 6Kg	329x280x83mm (AxBxE) - 6Kg	329x280x83mm (AxBxE) - 6Kg	
RS-485	329x280x83mm (AxBxE) - 6Kg	329x280x83mm (AxBxE) - 6Kg	329x280x83mm (AxBxE) - 6Kg	

Nominal values - tolerance  $\pm 5\%$

## Optics

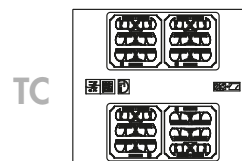
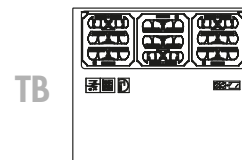
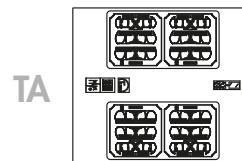

For any information about fluxes and wattages, please visit the tunnel section at [www.aecilluminazione.com](http://www.aecilluminazione.com)





## INTERIOR LIGHTING

### TA OPTIC

Symmetric optic on cross plane.

Typical applications:

1. Two-lane tunnels with central cable ladder.
2. Wide tunnels featured by four or more lanes, with two or more cable ladders.

### TB OPTIC

Asymmetric optic on cross plane.

Typical applications:

1. Three-lane tunnels with two cable ladders.
2. Lateral positioning.
3. Box tunnels.
4. Underpasses.

### TC OPTIC

Partially asymmetric optic on cross plane. This type of optic allows to light up the tunnel from a decentralised position without having to tilt the lighting device.

It also permits to contain the glaring effect maximising comfort and safety.

Typical applications:

1. Two-lane tunnels with decentralised cable ladder.

TA

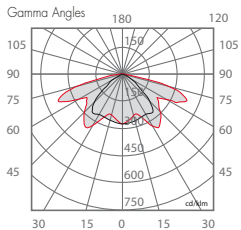

TB

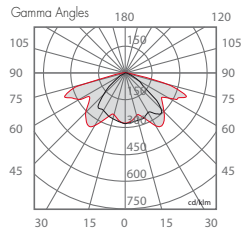

TC

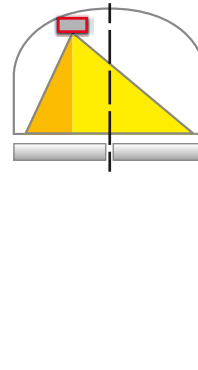
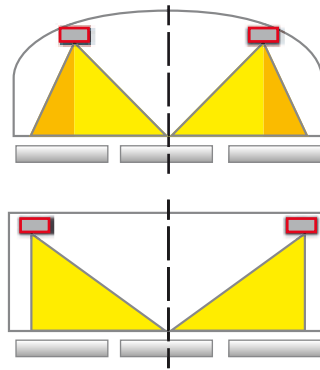
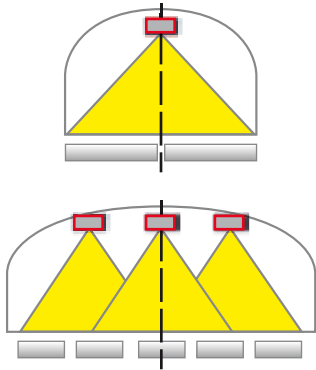
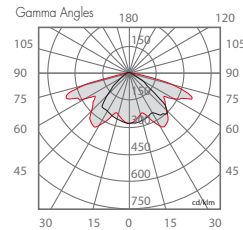

# ENTRANCE LIGHTING

## AS-6M/AS-6W OPTICS

Counter-beam symmetric optic on cross plane. This optic is available in two different transversal beams: medium (M) and wide (W) in order to optimise the lighting distribution according to the tunnel and pavements width. Typical applications:

1. Two-lane tunnels with central cable ladder.
2. Wide tunnels with two or more cable ladders.

### AS-6M/AS-6W

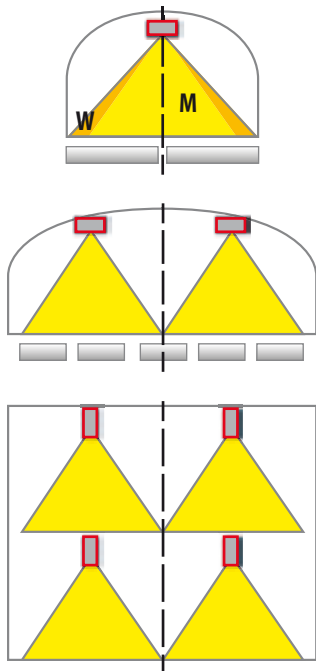
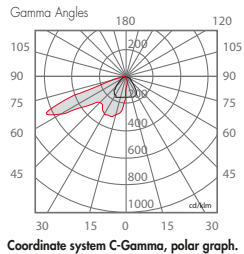

## AA-SX/AA-DX OPTICS

Counter-beam asymmetric optic on cross plane. This type of optic is available with right and left emissions. Typical applications:

1. Two-lane tunnel with decentralised cable ladder.
2. Lateral position.
3. Two or more lane box tunnels.

### AA-SX/AA-DX

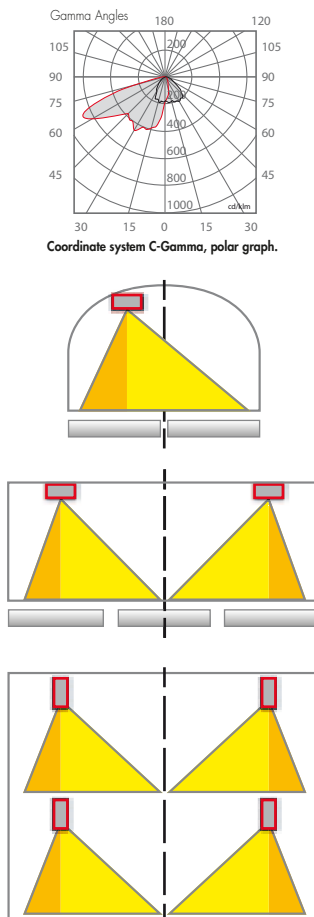
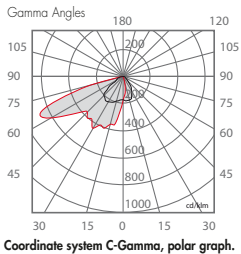

## SS-M OPTIC

Symmetric optic. Typical applications:

1. Two-lane tunnels with central cable ladder.
2. Wide tunnels with two or more cable ladders.

### SS-M

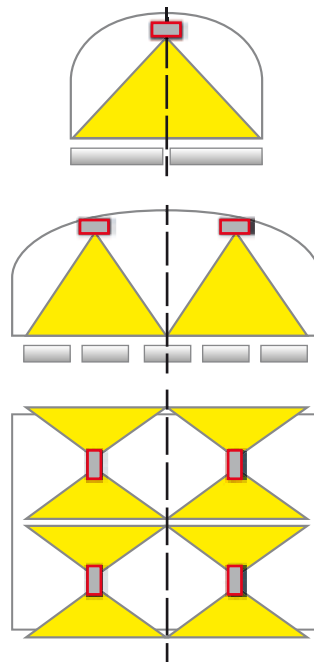
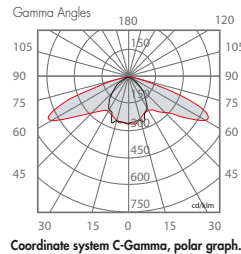

## OTTICA SA-M

Symmetric optics, asymmetrical on cross plane. Typical applications:

1. Lateral positioning.
2. Box tunnels.
3. Underpasses.

### SA-M

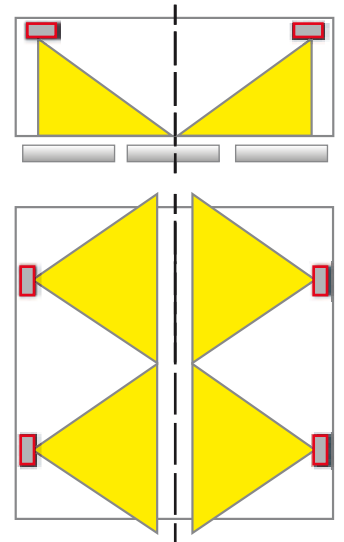
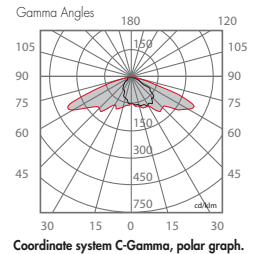

# THE REMOTE CONTROL SYSTEMS

LED technology represents the best solution for 24 hour lighting installations.

AEC tunnel lighting fittings are equipped with an electronic power supply unit able to adjust the luminous flux by acting on the current powering the LED's of the optical unit.

With the aim of increasing savings and considering critical variables such as outdoor natural light and traffic speed and density AEC proposes effective dimming solutions.

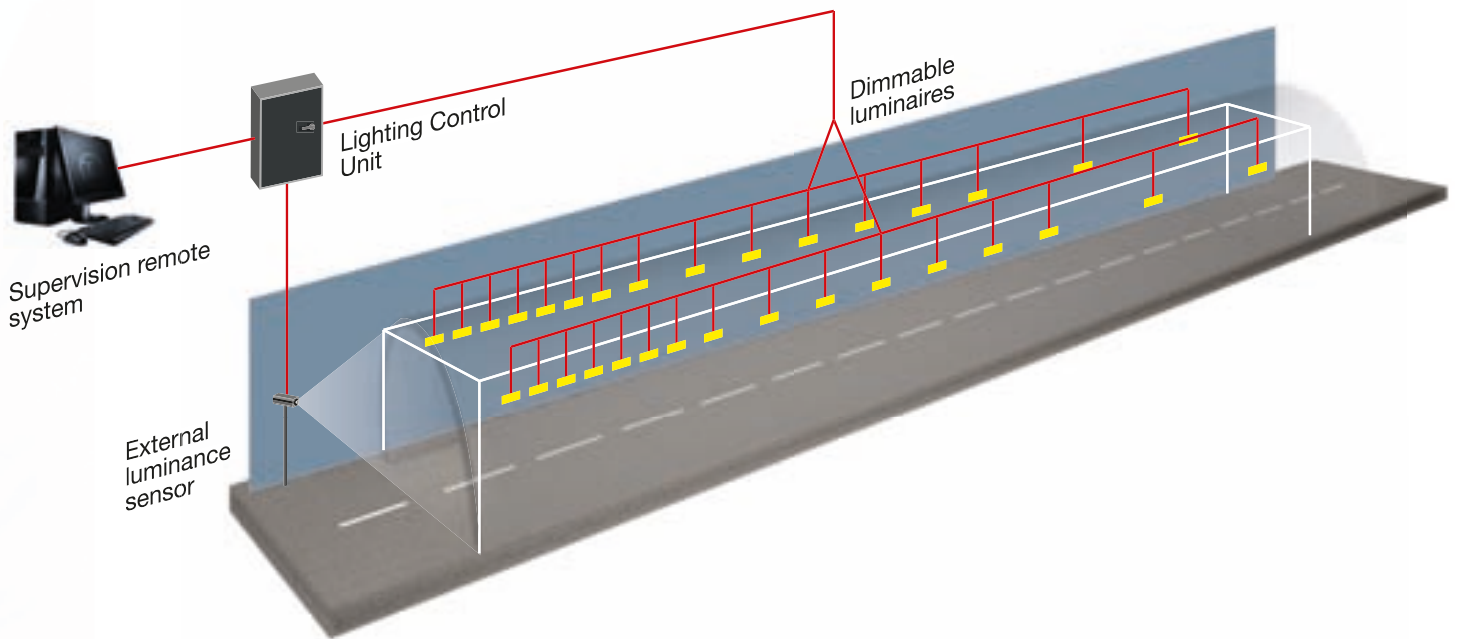

**PLM OPTION  
(luminous flux adjustment by means of conveyed waves)**

The reduction of the luminous flux may be associated with the punctual and remote monitoring of the single luminaire by means of a remotely managed control system. This option makes possible to control every single lighting point allowing to create customized lighting scenarios, to remotely monitor the power consumption of the system and to report

any failures. PLM can be integrated with other control systems such as traffic sensors, environmental sensors and SCADA system.

**RS-485 OPTION  
(luminous flux adjustment by means of RS-485 serial line)**

In alternative to the PLM option, the remote control of every single lighting point can be done by means of an additional cable (RS-485 serial line).

**DB OPTION  
(control of the dual power luminous flux by means of pilot wire)**

This option is primarily designed for underpasses or small installations where a simple and synchronized reduction of luminous flux is required. The unit comes with a dual power switch setting a regime of operation at full or reduced power according to the presence or absence of voltage on an additional conductor (pilot wire).

# LIGHT DESIGNING

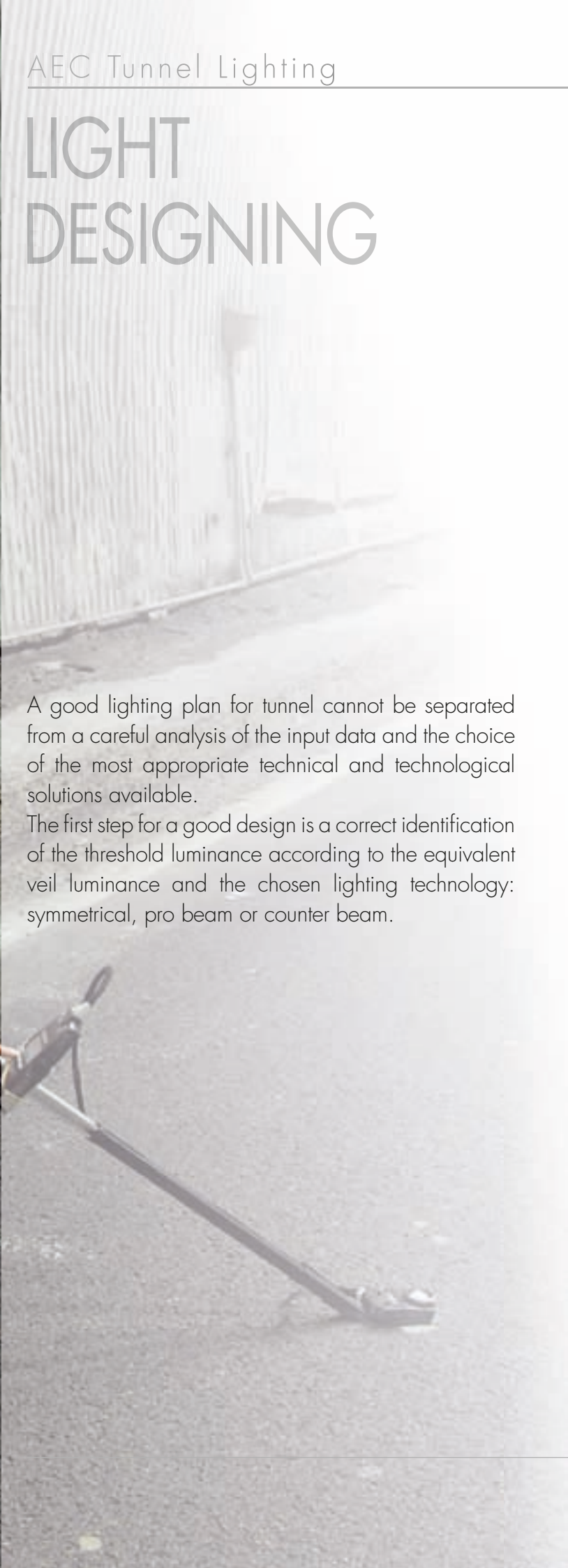

A good lighting plan for tunnel cannot be separated from a careful analysis of the input data and the choice of the most appropriate technical and technological solutions available.

The first step for a good design is a correct identification of the threshold luminance according to the equivalent veil luminance and the chosen lighting technology: symmetrical, pro beam or counter beam.



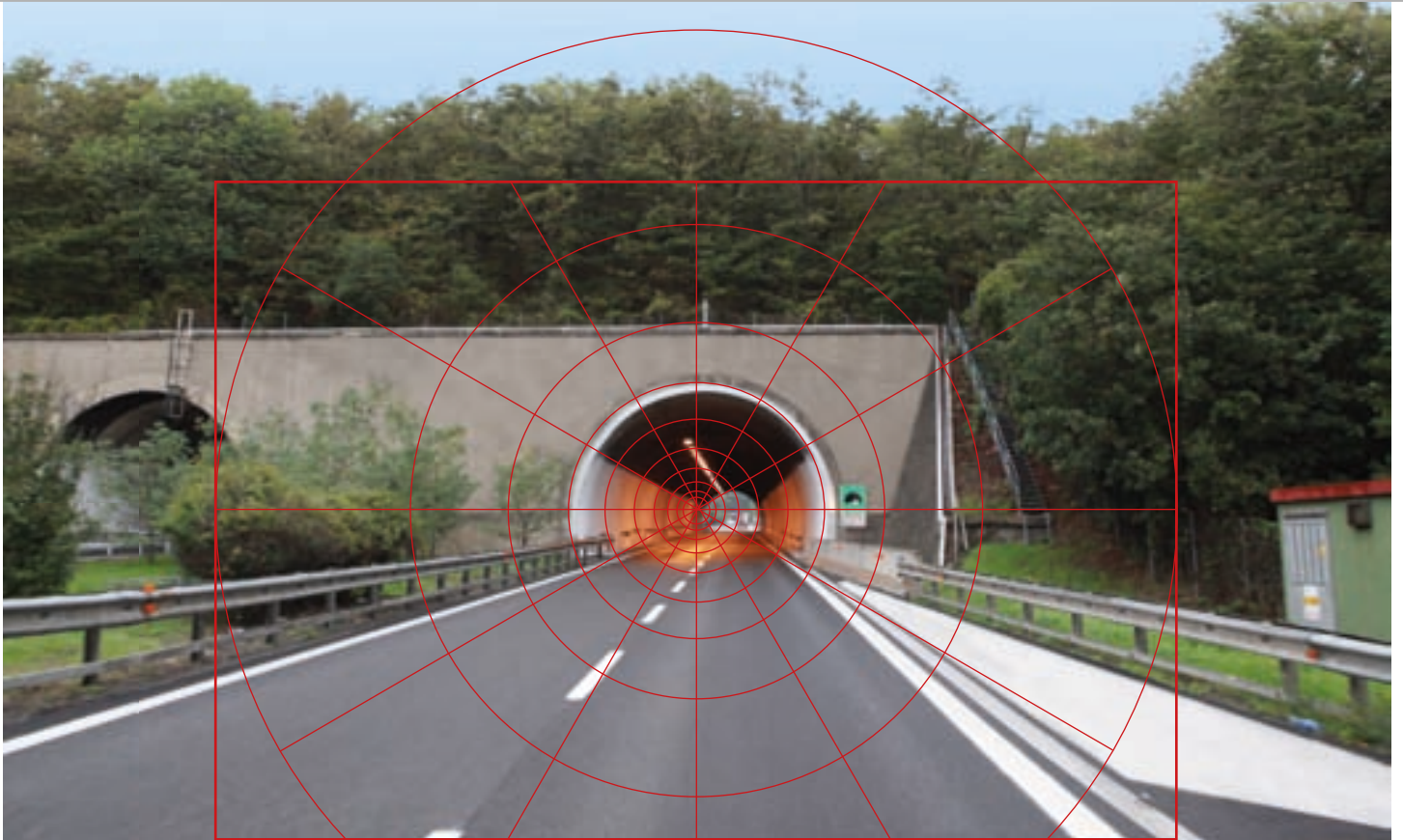

Adrian Diagram (perceived contrast method)



Counter beam



Pro beam



Symmetrical

The objective of the reinforcement lighting in the entrance zone is to guarantee the driver approaching the tunnel the perception of the obstacle. The visibility of the obstacle may vary depending on the lighting technology chosen: symmetrical, pro beam and counter beam.

A quality factor of contrast is associated with each of these systems (Qc). This factor, along with the value of the veiling luminance, determines the value of the threshold luminance (Lth).

Counter beam = 0.6  
 Symmetrical = 0.2  
 Pro beam = 0.1

Examples  
 $lv=470cd/m^2$

Counter beam =  $100cd/m^2$   
 Symmetrical =  $116cd/m^2$   
 Pro beam =  $152cd/m^2$

Consequently the choice of the technology effects both the threshold luminance (Lth) and the use of energy to achieve it. The counter beam solution is optimal for most of the tunnels (one way tunnels in particular). The symmetric solution can be useful in two-way tunnels where the adaptation curves of the entrances significantly overlap. The pro beam solution is not usually recommended.

# CASE STUDY

Reference standard: CIE 88



## CASE STUDY 1

### Tunnel Geometry

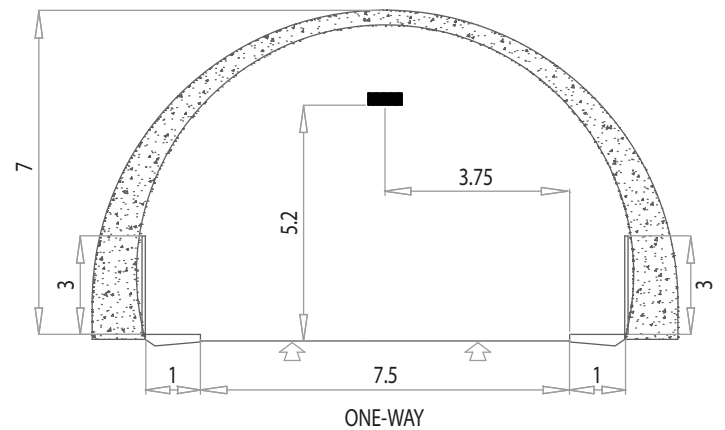

Carriageway width	7,5 m
Lanes number	2
Covering/material	R3, $q_0 = 0,07$
Right margin	1 m
Left margin	1 m
Wall height (right)	3 m
Covering/material	Diffus. 40%
Wall height (left)	3 m
Covering/material	Diffus. 40%

Calculation parameters	
Traffic speed	100 km/h
Entrance lane length	100 m
Entrance zone luminance	100 $cd/m^2$
Permanent luminance	4 $cd/m^2$
Maintenance factor	0.8

## PERMANENT LIGHTING

		Luminous Flux	Rated Power
Luminaire	TLED OB TB 6.5-54	7500lm	87W
Spacing	9 m		
Luminance	4,05 $cd/m^2$		
$U_0$	0,59		
$U_l$	0,86		
$T_i\%$	8		

## REINFORCEMENT LIGHTING

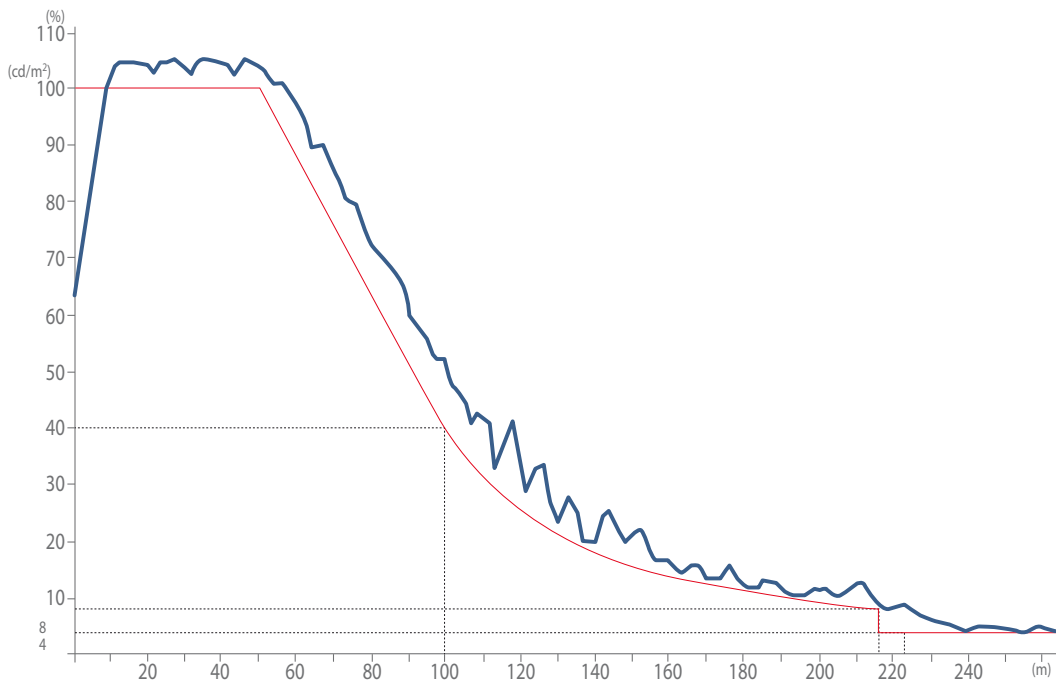

Observer Position 1 :  $x = -84,7, y = 1,88, z = 1,5$  ( $dx = 85,93$ )  
 Evaluation of L on the entire carriageway width

Luminaire	Luminous Flux	Rated Power	Quantity	Total Power
TLED 1F AS-6M 6.7-54	38050 lm	445 W	35	17,5kW
TLED 1F AS-6M 6.7-36	25600 lm	295 W	3	
TLED 1F AS-6M 6.7-18	13000 lm	151 W	6	
TLED 1F AS-6M 6.7-9	6750 lm	75 W	2	



# CASE STUDY

Reference standard: CIE 88

## CASE STUDY 2

### Tunnel Geometry

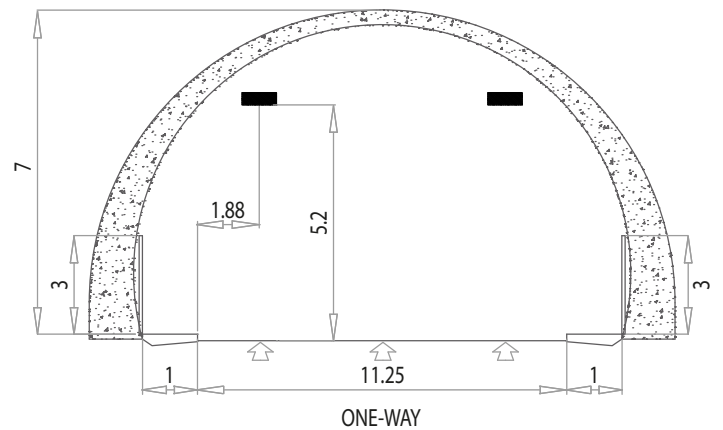

Carriageway width	11,25 m
Lanes number	3
Covering/material	R3, $\rho_0 = 0,07$
Right margin	1 m
Left margin	1 m
Wall height (right)	3 m
Covering/material	Diffus. 40%
Wall height (left)	3 m
Covering/material	Diffus. 40%

Calculation parameters	
Traffic speed	100 km/h
Entrance lane length	100 m
Entrance zone luminance	100 $\text{cd}/\text{m}^2$
Permanent luminance	4 $\text{cd}/\text{m}^2$
Maintenance factor	0.8

## PERMANENT LIGHTING

		Luminous Flux	Rated Power
Luminaire	TLED OB TB 6.5-54	7500lm	87W
Spacing	12 m		
Luminance	4,13 $\text{cd}/\text{m}^2$		
$U_0$	0,61		
$U_l$	0,82		
$T_i\%$	9,5		

## REINFORCEMENT LIGHTING

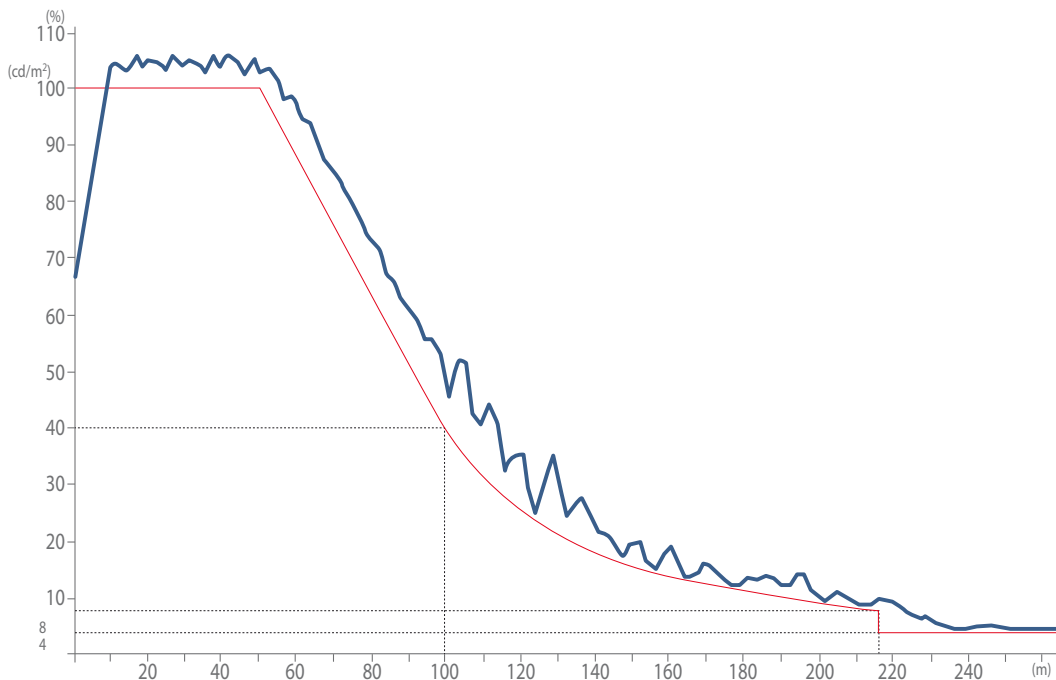

Observer Position 2 :  $x = -84,8, y = 5,63, z = 1,5$  ( $dx = 85,93$ )  
 Evaluation of L on the entire carriageway width

Luminaire	Luminous Flux	Rated Power	Quantity	Total Power
TLED 1F AS-6M 6.7-54	38050 lm	445 W	52	27.2 KW
TLED 1F AS-6M 6.7-36	25600 lm	295 W	6	
TLED 1F AS-6M 6.7-18	13000 lm	151 W	12	
TLED 1F AS-6M 6.7-9	6750 lm	75 W	6	

# CASE STUDY

Reference standard: CIE 88



## CASE STUDY 3 Tunnel Geometry

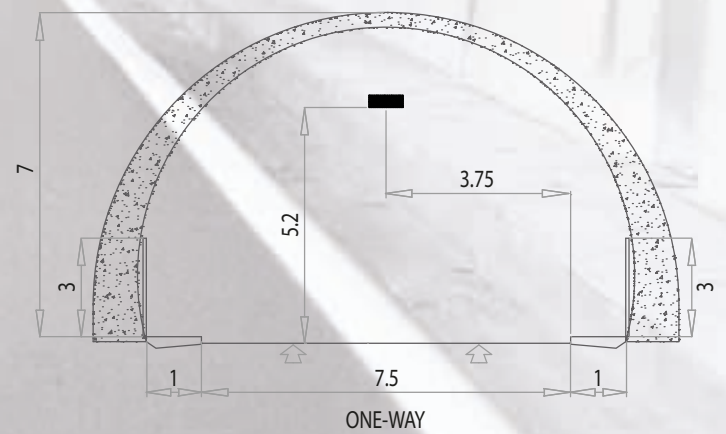

Carriageway width	7,5 m
Lanes number	2
Covering/material	R3, $\rho_0 = 0,07$
Right margin	1 m
Left margin	1 m
Wall height (right)	3 m
Covering/material	Diffus. 40%
Wall height (left)	3 m
Covering/material	Diffus. 40%

Calculation parameters	
Traffic speed	100 km/h
Entrance lane length	116 m
Entrance zone luminance	100 $\text{cd}/\text{m}^2$
Permanent luminance	4 $\text{cd}/\text{m}^2$
Maintenance factor	0.8

## PERMANENT LIGHTING

		Luminous Flux	Rated Power
Luminaire	TLED OB TA 6.5-54	7500lm	87W
Spacing	9 m		
Luminance	4,05 $\text{cd}/\text{m}^2$		
$U_0$	0,59		
UI	0,86		
Ti%	8		

## REINFORCEMENT LIGHTING

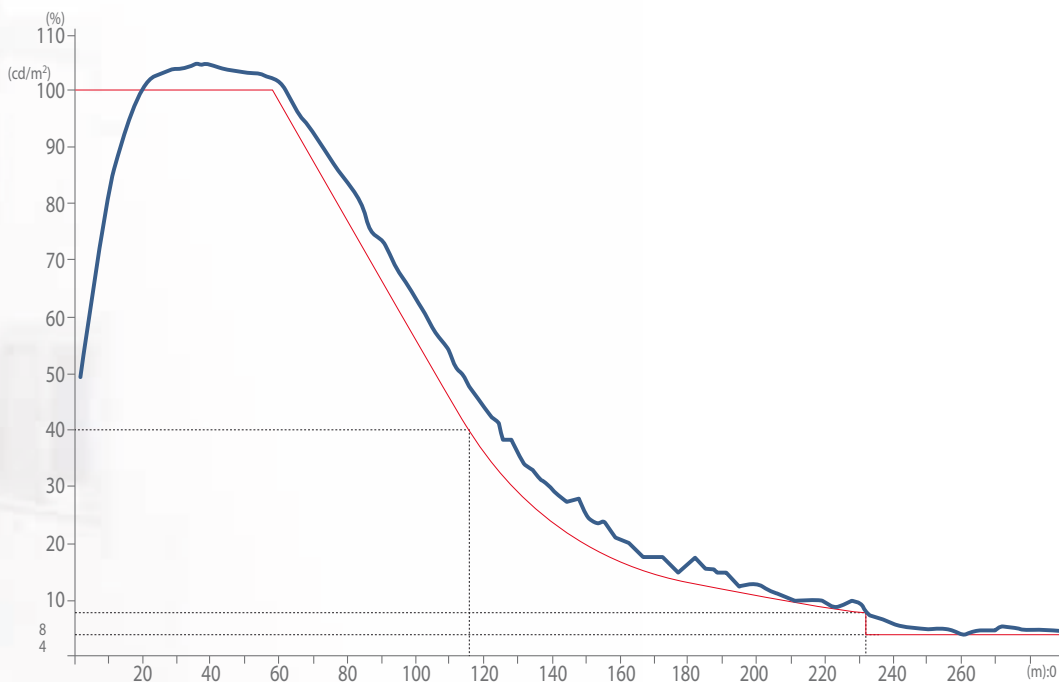

Observer Position 3 :  $x = -84, y = 1.88, z = 1.5$  (dx = 85.93)  
 Evaluation of L on the entire carriageway width

Luminaire	Luminous Flux	Rated Power	Quantity	Total Power
TLED 1F SS-M 6.7-54	36900 lm	445 W	58	27.7 KW
TLED 1F SS-M 6.7-36	24830 lm	295 W	4	
TLED 1F SS-M 6.7-18	12600 lm	151 W	5	



**AEC Illuminazione Srl**  
I-52010 Subbiano - Arezzo - Italy  
Via Righi, 4 - Zona Industriale Castelnuovo  
Tel. +39 0575 041110  
Fax +39 0575 420878  
[aec@aecilluminazione.it](mailto:aec@aecilluminazione.it)  
[www.aecilluminazione.com](http://www.aecilluminazione.com)